

JAL-OV7676 V1.0

OmniVision OV7676 DVP paralelo Interfaz Foco fijo 0.3MP VGA Módulo de cámara



Módulo de cámara No.	JAL-OV7676 V1.0
Sensor de imagen	OV7676
EFL	1.67 mm
F.NO	3.0
Pixel	640 x 480 (VGA)
Ángulo de visión	69°
Tipo de lente	1/7.5 pulgada
Dimensiones de la lente	5 x 5 x 3.05 mm
Tamaño del módulo	19.6 x 12.5 mm
Tipo de módulo	Foco fijo
Interfaz	DVP paralelo

N. ° de pieza del conector de acoplamiento. FH12-24S-0.5SH



Conector de acoplamiento en la placa principal. Se vende por separado.

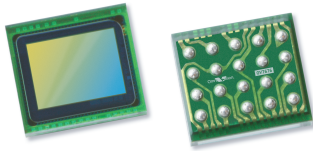

OV7676 VGA product brief



Cost-Effective VGA Sensor Delivers Best-In-Class Pixel Performance to Wide Range of Consumer Applications



available in
a lead-free
package

OmniVision's high performance OV7676 is a cost-effective 1/7.5-inch system-on-a-chip (SOC) VGA sensor that brings best-in-class pixel performance to a wide range of applications, including mobile phones, tablets, wearables, notebooks, and IP network cameras.

Utilizing OmniVision's 3-micron OmniPixel3-HS™ technology, the OV7676 achieves best-in-class low-light sensitivity, signal-to-noise ratio, full-well capacity (FWC), quantum efficiency and low-power consumption. The OV7676 supports serial peripheral interface (SPI) and digital video port (DVP) interface customization for both smartphone and feature phone platforms.

When used as a front-facing camera solution in smartphones, tablets and notebooks, the OV7676 also supports video-in-video functionality, allowing users to record and stitch together video being recorded simultaneously by the front- and rear-facing cameras.

The OV7676 fits into a 2.73 x 2.47 mm chip-scale package (CSP).

Find out more at www.ovt.com.



Applications

- Mobile Phones
- PC Multimedia
- Toys
- Digital Still Cameras

Product Features

- support for image sizes: VGA (640x480), QVGA (320x240) and CIF (352x288)
- support for horizontal and vertical sub-sampling
- support for output formats: RAW RGB and YUV output with DVP and SPI port
- automatic image control functions:
 - automatic exposure control (AEC)
 - automatic white balance (AWB)
 - automatic black level calibration (ABLC)
- on-chip phase lock loop (PLL)
- image quality controls: defect pixel correction and lens shading correction
- built-in 1.8V regulator for digital block
- support for black sun cancellation
- capable of maintaining register values at software power down
- standard serial SCCB interface
- programmable controls for frame rate, mirror and flip, AEC/AGC, and windowing
- parallel I/O tri-state configurability and programmable polarity

OV7676

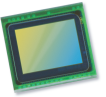

Ordering Information

- OV07676-H20A (color, lead-free, 20-pin CSP5)

Product Specifications

- active array size: 640 x 480
- maximum image transfer rate:
 - VGA: 30 fps
 - QVGA: 60 fps
 - CIF: 30 fps
- power supply:
 - analog: 2.8V ±5%
 - core: 1.8VDC ±5% (internal regulator)
 - I/O: 2.8V, 1.8V
- sensitivity: 1900 mV/lux-sec
- power requirements:
 - I_{DD-A}: 15 mA
 - I_{DD-IO}: 1.7 mA
 - XSHUTDOWN: <15 μA
- shutter: rolling shutter
- temperature range:
 - operating: -30°C to +70°C junction temperature
 - stable image: 0°C to +50°C junction temperature
- max S/N ratio: 38 dB
- dynamic range: 70.4 dB @ 8x gain
- output formats: YUV422, RAW RGB
- maximum exposure interval: 506 x t_{ROW}
- lens size: 1/7.5"
- pixel size: 3 μm x 3 μm
- lens chief ray angle: 26.6°
- dark current: 6 mV/sec @ 60°C junction temperature
- input clock frequency: 6 - 27 MHz
- image area: 1962 μm x 1482 μm
- scan mode: progressive
- package dimensions:
 - CSP5: 2734 μm x 2474 μm

Functional Block Diagram

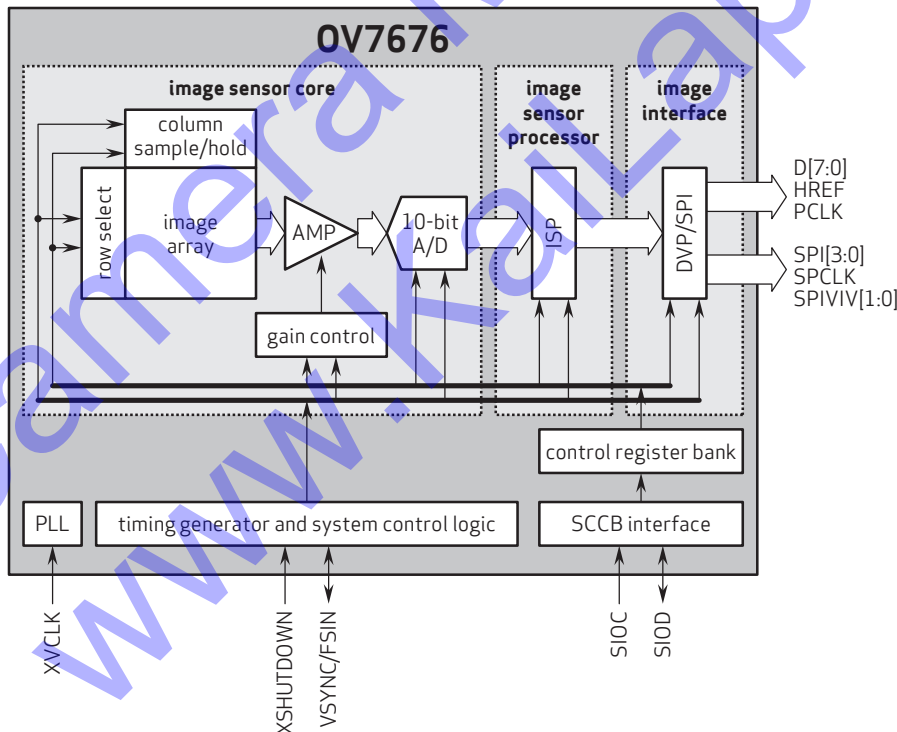

4275 Burton Drive
Santa Clara, CA 95054
USA

Tel: +1 408 567 3000
Fax: +1 408 567 3001
www.ovt.com

OmniVision reserves the right to make changes to their products or to discontinue any product or service without further notice. OmniVision, the OmniVision logo and OmniPixel are registered trademarks of OmniVision Technologies, Inc. OmniPixel3-H5 is a trademark of OmniVision Technologies, Inc. All other trademarks are the property of their respective owners.



OmniVision